

Digital crane scale

Model: OCS-SP



Main technical data

Accuracy Standard	According to OIML class III
Display	30mm (1.2") 5digits LCD/LED
Filtering	Low, Medium or High selectable
Units	Kilograms, Pounds or Newtons selectable
Resolution	2000 to 3000 divisions standard up to 15,000 available
Zero Range	4% F.S.
Tare Range	100% F.S.
Overload Indication	100% F.S. + 9e
Max. Safety Load	125% F.S.
Ultimate Load	400% F.S.
Battery Type	Fully sealed Lead-Acid battery, 6V/5Ah
Battery Life	≥60 hours
Adapter	DC 9V/1000mA
Operating Temperature Range	- 20 C ~ + 50 C
Operating Humidity	≤85% RH under 20 C
Remote Controller Distance	Max. 15m
Battery of Remote Controller	AAA battery, 1.5V x 2
Acceleration of Gravity	9.793, Can be regulated

Features

- ◆ **Enclosure:**
NEMA 12/IP54 powder coated Die-Casting Aluminum, very light, easy to bring.
- ◆ **Multi-weighing units:**
Kg, lb, N are selectable, kg are default unit.
- ◆ **Multi-function operation:**
Tare, Zero, Auto zero tracking, Total, Hold, Overload warning and record, operated through infrared remote controller.
- ◆ **User-friendly design:**
Large red 5 digit LED display (digit height 30mm), Battery Operated with low battery indication, Automatic turn off, power-saving function.
- ◆ **Gravity regulation:**
The acceleration of gravity can be regulated through remote controller according to different places value.
- ◆ **Multi options:**
RS-232-continuous or on demand data output, user-selectable.

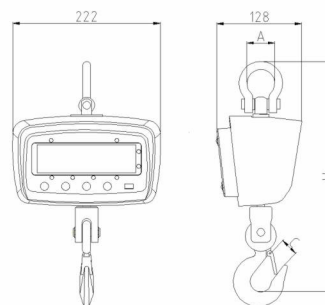

Dimensions and Specifications

MODEL	Cap.(kg)	Resolution (kg)	A(mm)	C(mm)	H(mm)	N.W(kg)	G.W.(kg)
OCS-SP-005	50	0.02	34	25	370	4	5
OCS-SP-01	100	0.05	34	25	370	4	5
OCS-SP-02	200	0.1	34	25	370	4	5
OCS-SP-03	300	0.1	34	25	370	4	5
OCS-SP-05	500	0.2	42	27	390	4.5	5.5
OCS-SP-1	1000	0.5	42	27	390	4.5	5.5